

Li Time

Originate from Ampere Time

LiFePO4

12V 100Ah

Trolling Motor
and More

PRODUCT (100A BMS)

MANUAL

Lithium Iron Phosphate (LiFePO4) Battery

www.litime.com

service@litime.com

technicalsupport@litime.com

PRODUCT OVERVIEW

12.8V 100AH BATTERY

Operating Voltage: 12.8V

Charging Voltage: $14.4 \pm 0.2V$

Recommend Charge Current: 20A (0.2C)

Max Continuous Discharge Current: 100A

Max. Continuous Output Power: 1280W

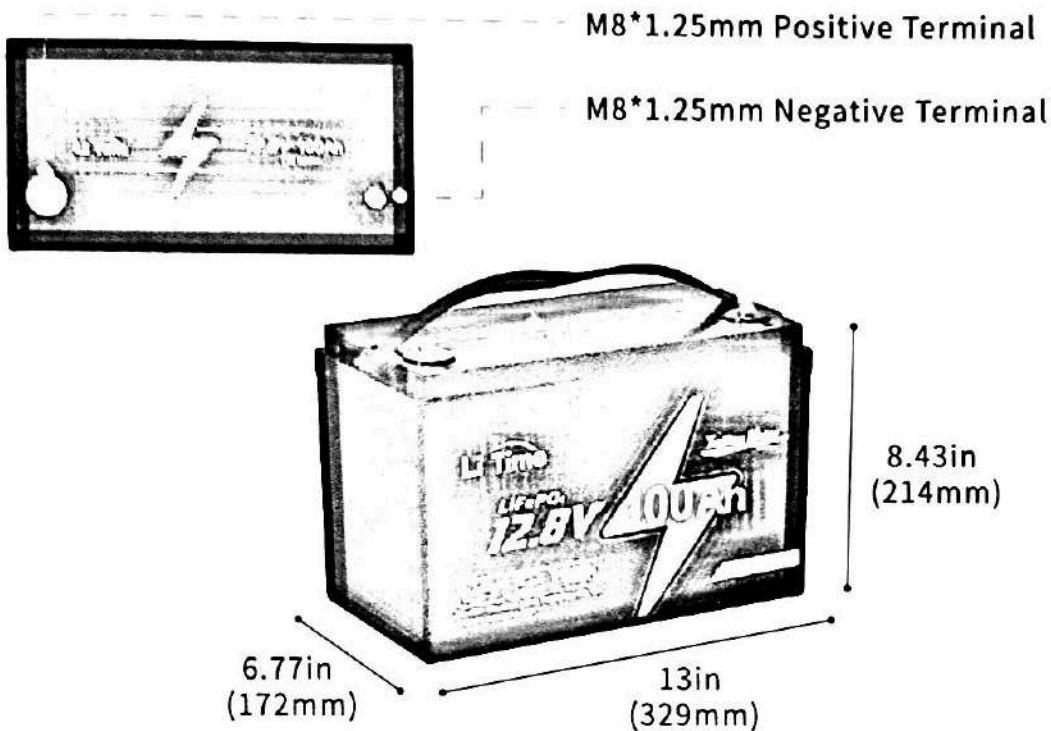

ADDITIONAL COMPONENTS

M8- 5/8" (16mm) Terminal Bolts *2

The terminal bolts are used to secure multiple cable lugs to a single battery terminal. The bolts can be replaced with M8 bolts of other lengths based on actual needs.

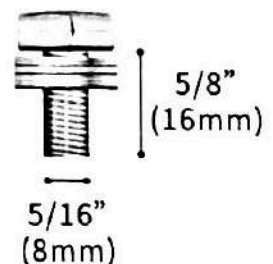

Insulating Caps for Bolts *2

IMPORTANT SAFETY INSTRUCTION

| Please keep the battery away from heat sources, sparks, flames, and hazardous chemicals.

| Maintain Adequate Ventilation and Heat Dissipation

Place the battery in a well-ventilated area with sufficient heat dissipation to prevent overheating and damage.

| Size the Battery Cables and Connectors Appropriately

Use high-stranded copper connectors and heavy gauge cables to handle possible battery loads. Make sure to keep identical cable lengths.

Avoid accidents caused by unsuitable connectors or cables that make the connection a heat source during battery operation.

| Please tighten all cable connections, as loose cable connections can cause terminal meltdown or fire.

| DO NOT puncture, drop, crush, burn, penetrate, shake, or strike the battery.

The battery should be securely fastened during handling to prevent impact or dropping.

It should be safely secured to a solid plane and the cables safely tied to a suitable location to avoid arcing and sparking due to friction.

DO NOT press it by placing heavy stuff on top of it for long periods, which may damage it due to an internal short circuit.

| DO NOT immerse the battery in water whether the battery is in use or on standby.

| DO NOT open, dismantle, or modify the battery.

| DO NOT touch the exposed electrolyte or powder if the battery casing is damaged.

| Uncovered electrolyte or powder that has contacted the skin or eyes MUST be flushed out with plenty of clean water immediately. Seek medical attention afterward.

| Avoid Short Circuit

Please use circuit breakers, fuses, or disconnects that have been properly sized by certified electricians, licensed installers, or regional code authorities to protect all the electrical equipment in your system. The battery has a built-in battery management system (BMS) that protects the battery cells from over-charge, over-discharge, and over-current, however this alone will not protect your system from severe electrical conditions.

| Trained and certified technicians are required for safe and reliable installation. This product manual can only serve as a guideline as it cannot cover all possible scenarios.

| Verify Correct Polarity

Please verify the polarity before connecting the wiring. Reverse polarity can and will destroy the battery and other electrical equipment. Use a multimeter to determine proper polarity.

| Avoid Exposed Metal Terminals or Connectors

The terminals of this battery are always live. Avoid exposed metal terminals or connectors; DO NOT place tools on the terminals or touch them with bare hands; DO NOT short circuit or use outside of specified electrical ratings.

| DO NOT dispose of the battery as household waste. Please use recycling channels in accordance with local, state, and federal regulations.

WARNING

| Batteries are potentially dangerous and proper precautions must be taken during operation and maintenance.

| Improper use of the battery can lead to battery failure or other potential damage.

| Improper configuration, installation, or use of related equipment in the battery system may damage the battery and other related equipment.

| Please wear proper personal protective equipment when working on the battery.

| Battery installation and maintenance must be performed by trained and certified technicians.

| Failure to follow the warnings above can result in potential damage.

**If you have any questions or need any help,
please feel free to contact us (and leave your contact phone number)
at service@litime.com,
we will offer phone or email support in 12hrs.**

WHAT TO DO AFTER RECEIVING THE BATTERY

Step **1** CONTACT US at service@litime.com to activate the FIVE-YEAR WARRANTY

Step **2** PULL OUT Insulating Plugs

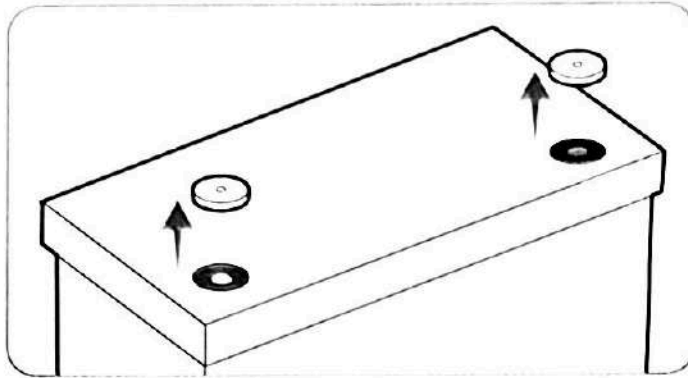

Step **3** TEST The Battery Voltage with a Multimeter

≥12V To Next Step

<12V Contact us at service@litime.com to help solve the problem.

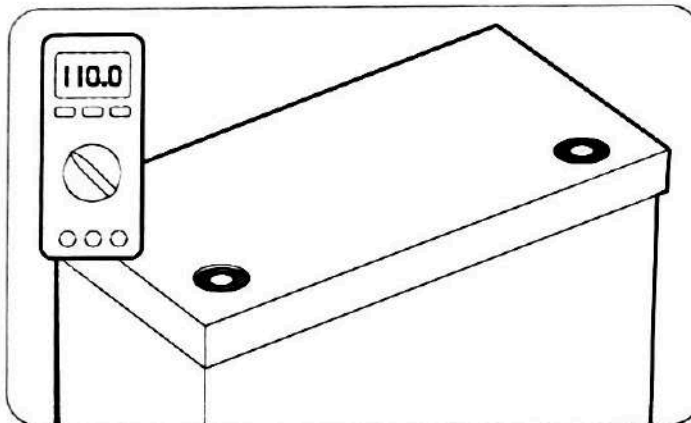

TIGHTLY SCREW IN Post Bolts

⚠ Please tightly screw in the post bolts. Having loose battery terminals will cause the terminals to build up heat resulting in damage to the battery.

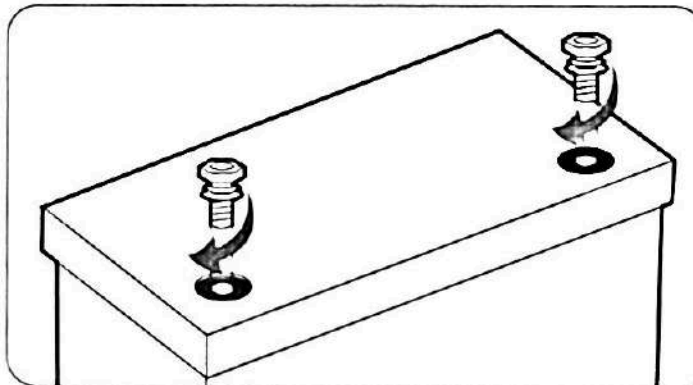

Step
5

FULLY CHARGE The Battery
(Refer to Page 04 for battery charging methods)

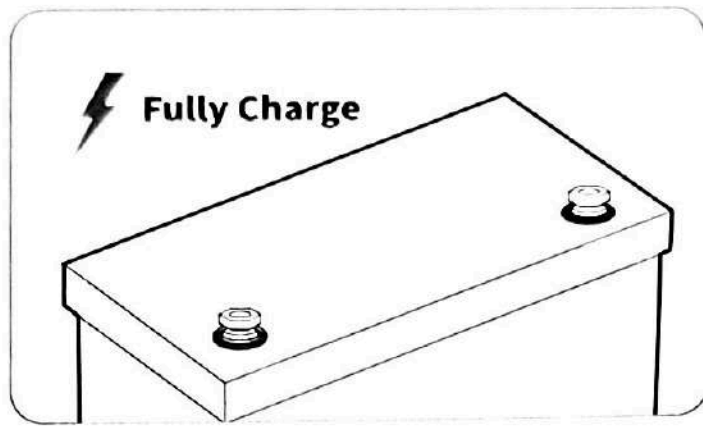

Step
6

CONNECT To Use

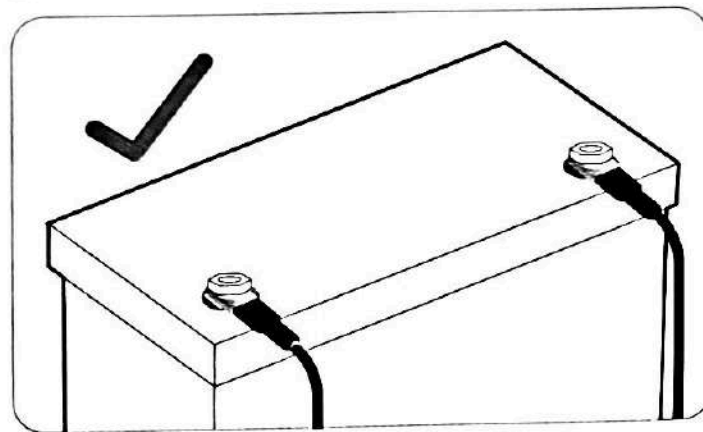

Step
7

Cover with **INSULATING CAPS** when **STORED**

⚠ Please do not cover the post bolts with insulating caps when using the battery.

Please put on the insulating covers to avoid metal or conductive objects touching the positive and negative terminals of the battery at the same time, otherwise it is likely to cause a short circuit.

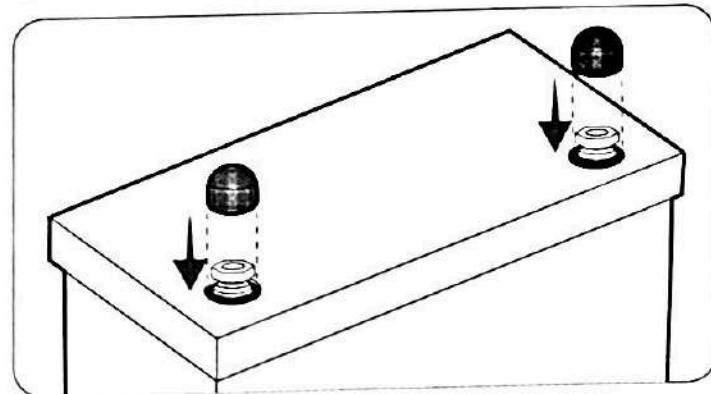



CONTENTS

BATTERY PARAMETERS	page
	01

THINGS TO KNOW BEFORE USING	page
	03
Long Term Storage	03

CHARGING METHODS	page
	04

	Battery Charging Logic	04
Background Information	LiFePO4 and Lead-Acid Battery Charging Curve	04
	LiFePO4 Battery Charging Mode	04
	Solar Panel(s) & Controller	05
Method I	Solar Panel	
	Controller	
	Controller Settings	
Method II	Battery Charger	06
Method III	Alternator / Generator	06

HOW TO ESTIMATE THE BATTERY CAPACITY	page	07
State of Charge (SOC)		07

RECOMMENDED CABLE SIZING	page	08
---------------------------------	------	-----------

SERIES / PARALLEL CONNECTION	page	09
-------------------------------------	------	-----------

The Premise of Connection		09
---------------------------	--	----

Limitation for Series/Parallel Connection		09
---	--	----

How to Connect Batteries		10
--------------------------	--	----

 Step 1 Wear Insulating Gloves

 Step 2 Voltage Balancing Before Connection

 Step 3 Battery-to-Battery Connection

 Step 4 Total Input & Output Connection

 Step 5 Rebalancing Every Six Months

 Wiring Diagram Reference

INVERTER SETTINGS	page	16
--------------------------	------	-----------

WHAT TO DO WHEN THE BATTERY STOPS WORKING?	page	17
---	------	-----------

BATTERY-PACK MAIN PARAMETERS

Cell	Prismatic LiFePO4 Battery
Nominal Voltage	12.8V
Rated Capacity	100Ah
Energy	1280Wh
Internal Resistance	$\leq 40\text{m}\Omega$
Cycle Life	4000 times (25°C, 0.2C, 100% DOD)
Battery Management System (BMS) Board	100A
Charge Method	CC/CV
Charge Voltage	14.4V \pm 0.2V
Recommend Charge Current	20A (0.2C)
Max. Continuous Charge Current	100A
Max. Continuous Discharge Current	100A
Max. Discharge Current 5 Seconds	300A to 500A
Max. Continuous Output Power	1280W

Dimension	L13*W6.77*H8.43 inch
	329*172*214mm
Housing Material	ABS (Flame Retardant Plastic)
Protection Class	IP65
Temperature Range	Charge: 0°C to 50°C / 32°F to 122°F
	Discharge: -20°C to 60°C / -4°F to 140°F
	Storage: -10°C to 50°C / 14°F to 122°F

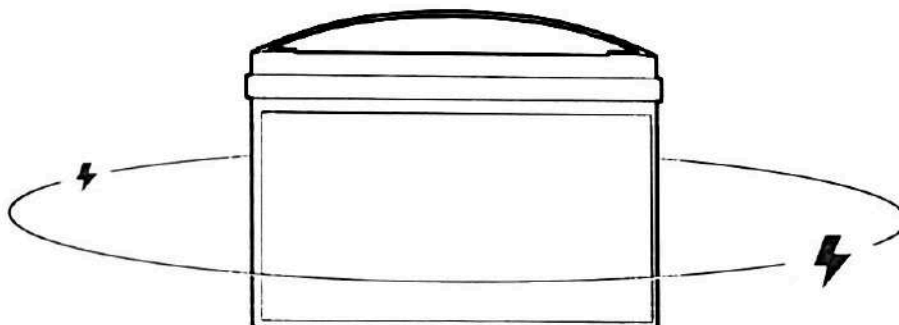

THINGS TO KNOW BEFORE USING

! When using the battery, please be careful to **avoid metal or conductive objects touching the positive and negative poles of the battery at the same time**, otherwise it may cause a short circuit.

! **Install the battery upright with post bolt facing up**, and it could not be mounted upside down. If you need to mount the battery at its side, please contact service@litime.com to confirm the direction.

! **Tightly screw in the post bolts**. Having loose battery terminals will cause the terminals to build up heat resulting in damage to the battery.

! This battery is not intended to be used to start any devices, please **DO NOT use it as a starting battery**.

! Suggestions for **Long-term Storage**:

○ Temperature

The battery can be operated at a temperature of -20°C to 60°C / -4°F to 140°F , and a temperature between 10°C to 35°C / 50°F to 95°F is ideal for long-term storage. Store in a fireproof container and away from children.

○ Capacity

For a longer-lasting product, it is best to store your battery at a 50% charge level and recharge every three months if it is not going to be used for a long time.

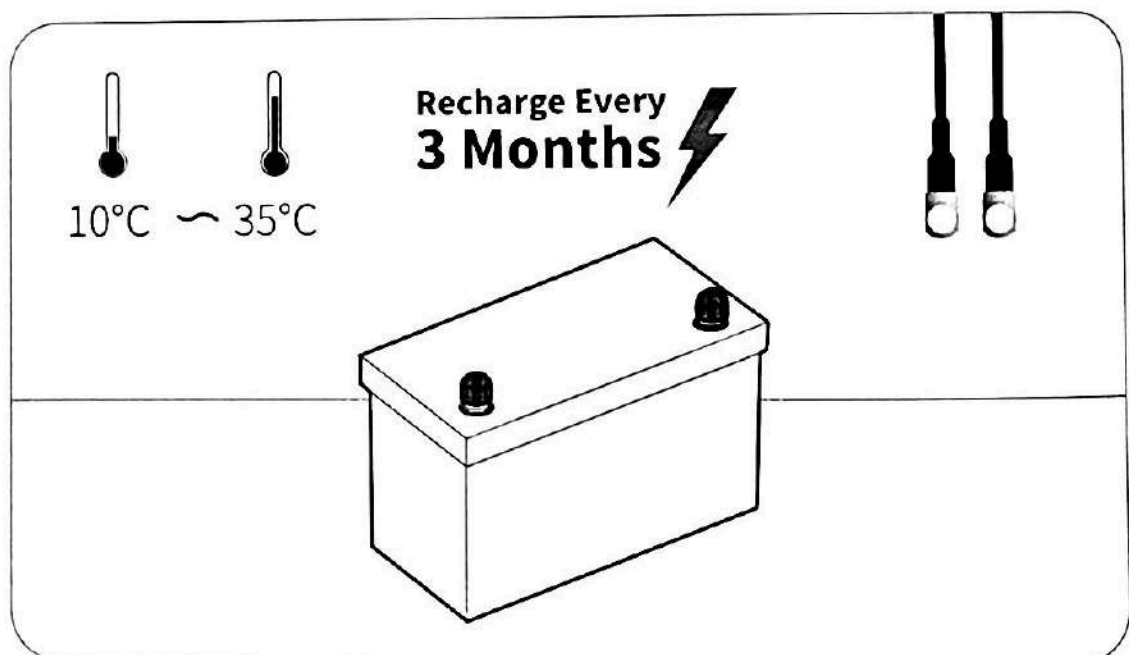

CHARGING METHODS

BATTERY CHARGING LOGIC

The material characteristics of the LiFePO₄ battery determine that its charging curve is obviously different from that of a lead-acid battery. Compared with a lead-acid battery, the LiFePO₄ battery has a simpler charging process and mode. Therefore, it is recommended to select LiFePO₄ for your charging mode.

If LiFePO₄ mode is not available, please refer to the recommended parameters on Page 05~06 for setting.

LIFEPO4 AND LEAD-ACID BATTERY CHARGING CURVE

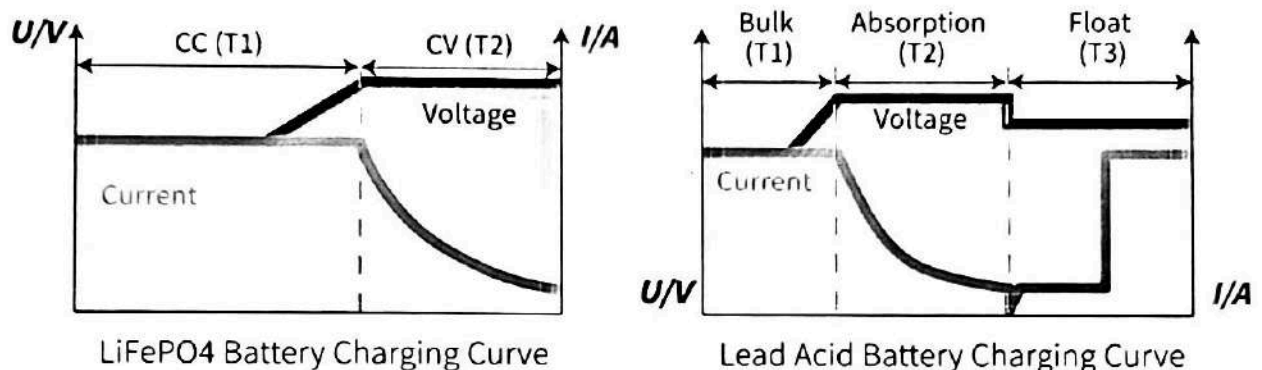

LIFEPO4 BATTERY CHARGING MODE

○ CC (Constant Current) Phase (T1)

In the beginning, a discharged battery will be charged with a constant current and voltage will be climbing steadily until reaching the constant voltage setpoint which varies for different charging methods.

○ CV (Constant Voltage) Phase (T2)

The battery maintains a constant voltage during this phase while the current gradually decreases to 2A (0.02C) which is also known as tail current^①. At this point, the charging is cut off and the battery is fully charged.

① Tail Current (A) = Battery Capacity * 0.02C. E.g., 100Ah*0.02C= 2A tail current.

HOW TO ESTIMATE THE BATTERY CAPACITY

STATE OF CHARGE (SOC)

The battery capacity could be roughly estimated by its resting voltage (not charging/discharging voltage).^①

Since the voltage of each battery is slightly different, and the voltage measurement is affected by the measuring instrument, ambient temperature, etc., the following parameters are for reference only. The actual SOC of the battery is based on the discharge capacity under load.

Resting Voltage: The voltage is measured after the battery has been disconnected from the charger and loads with zero current, and left alone for 3 hours.

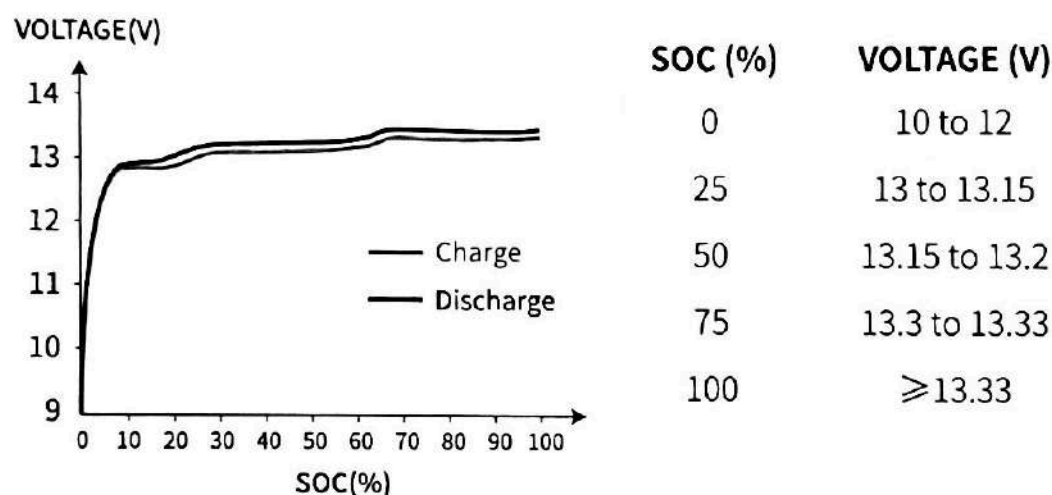

①Based on the characteristics of LiFePO₄ batteries, the voltage measured by all LiFePO₄ batteries during charging/discharging is not the real voltage of the battery. Therefore, after charging/discharging and disconnecting the battery from the power source, the voltage of the battery will gradually drop/increase to its real voltage.

RECOMMENDED CABLE SIZING

Battery cables should be properly sized to handle the expected load. Refer to the table below for amperage ratings for different sizes of copper cables.

PVC COPPER CABLE SIZE (AWG/mm ²)	AMPACITY (A)
14 (2.08)	20
12 (3.31)	25
10 (5.25)	35
8 (8.36)	50
6 (13.3)	65
4 (21.1)	85
2 (33.6)	115
1 (42.4)	130
1/0 (53.5)	150
2/0 (67.4)	175
4/0 (107)	230

The above values are from NEC Table 310.15(B)16 for copper cables rated at 167°F (75°C) operating at an ambient temperature not exceeding 86°F (30°C). Cables longer than 6 feet (1829 mm) or ambient temperature higher than 86°F (30°C) may require heavier gauges to avoid excessive voltage drops with undersized ones.

SERIES / PARALLEL CONNECTION

THE PREMISE OF CONNECTION

To connect in series or /and parallel, batteries should meet the below conditions:

- identical batteries with the same battery capacity (Ah) and BMS (A);
- from the same brand (as lithium battery from different brands has their special BMS);
- purchased in near time (within one month).

LIMITATION FOR SERIES/PARALLEL CONNECTION

Support connecting up to 16 identical batteries for up to:
4 in series as 48V (51.2V) battery system/
4 in parallel as 400Ah battery system.

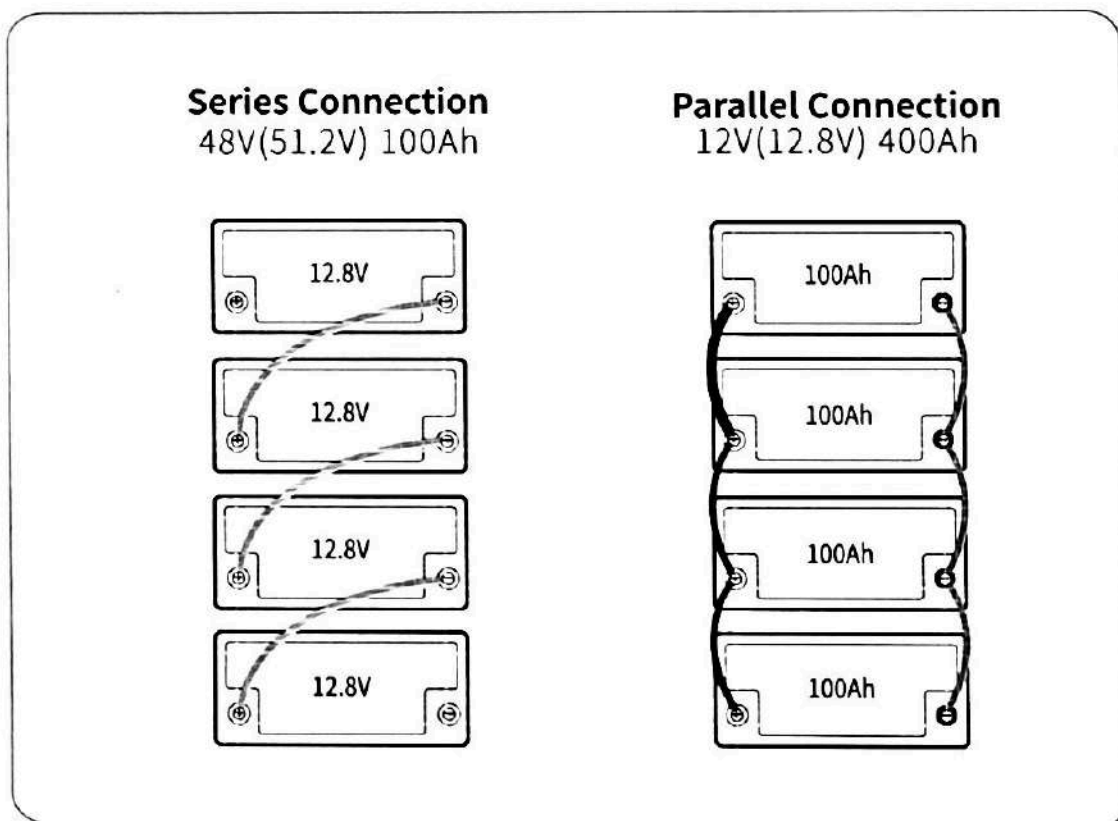

HOW TO CONNECT BATTERIES

Step 1 Wear Insulating Gloves

Wear insulating gloves for protection before connecting. Please pay attention to operation safety in the process of connection.

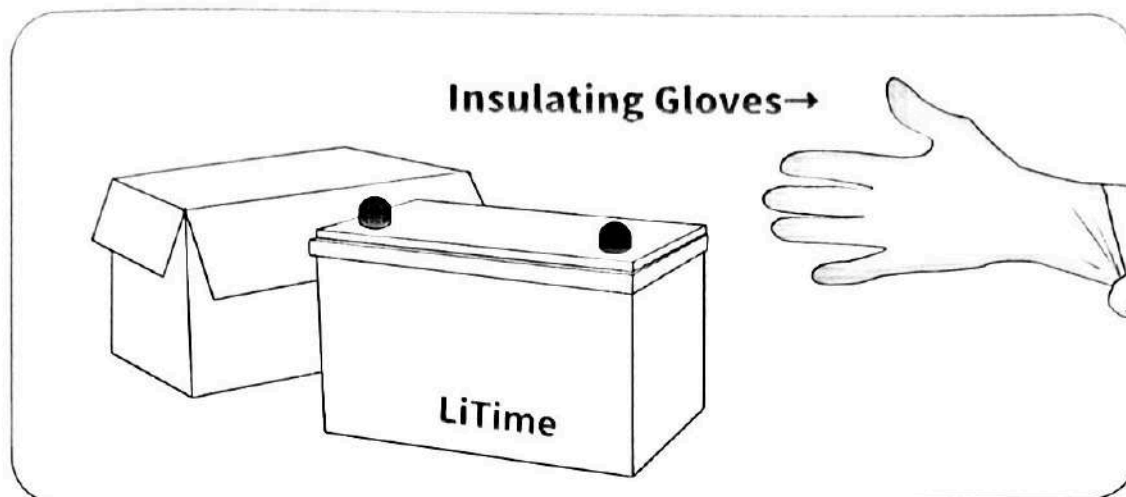

Step 2 Voltage Balancing Before Connection

Below two steps are necessary to reduce the voltage difference between batteries and let the battery system perform the best of it in series or/ and in parallel.

Step 1 Fully charge the batteries separately.
(voltage at rest: $\geq 13.33V$)

Step 2 Connect all of the batteries in parallel, and leave them together for 12~24hrs.

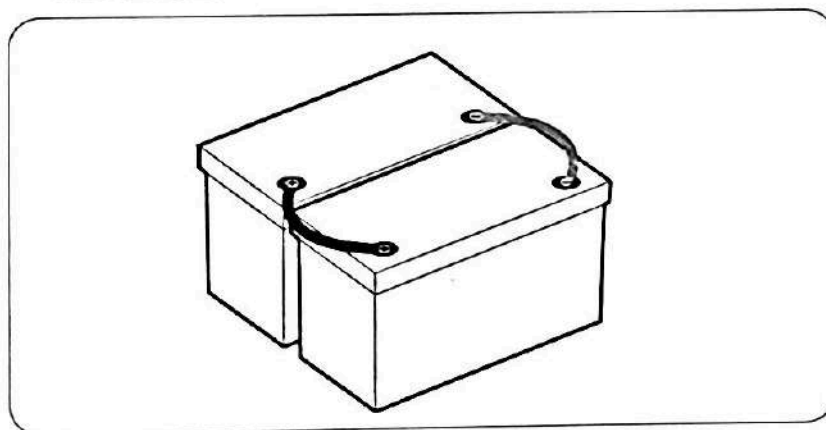

Step 3 They're now ready for the connection.

I Step3 Battery-to-Battery Connection

- #1 Connect Batteries in Series **+** to **-**

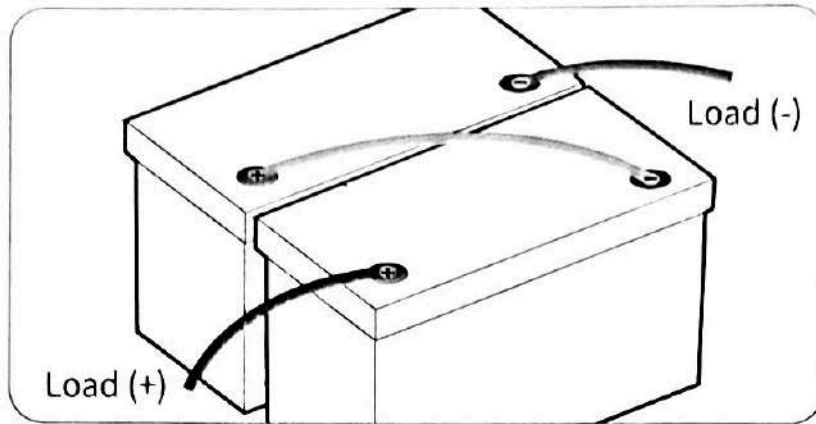

After series connection, the voltage of the battery system will be doubled according to the number of batteries you connect.

E.g. If two 12V 100Ah batteries are connected in series, the battery system will be 24V (25.6V) 100Ah.

- #2 Connect Batteries in Parallel **+** to **+** **-** to **-**

Refer to Page 13 for total input & output connection

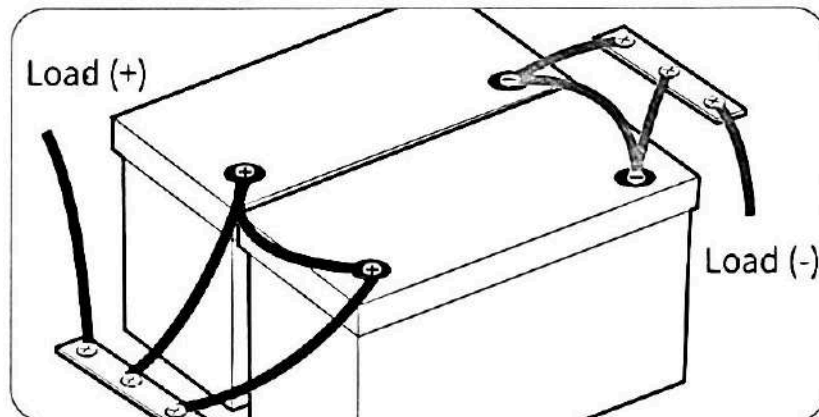

After parallel connection, the capacity of the battery system will be doubled according to the number of batteries you connect.

E.g. If two 12V 100Ah batteries are connected in parallel, the battery system will be 12V (12.8V) 200Ah.

○ #3 Connect Batteries Both in Series & Parallel ①

Connect in parallel first, then series.

Step
1

Connect the batteries in parallel.

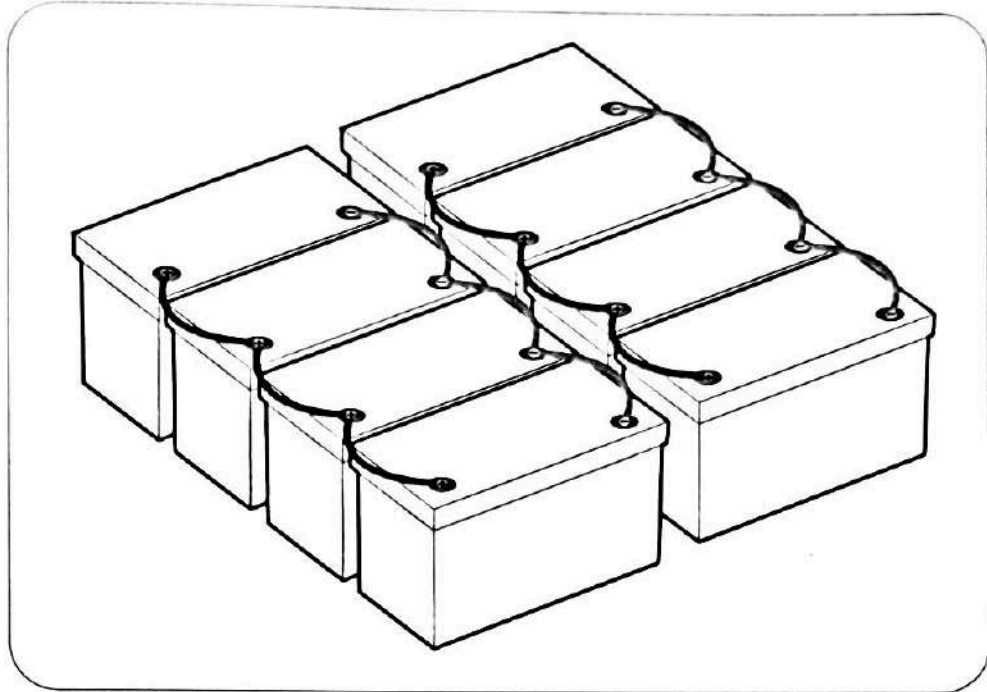

Step
2

Connect the paralleled battery systems in series.

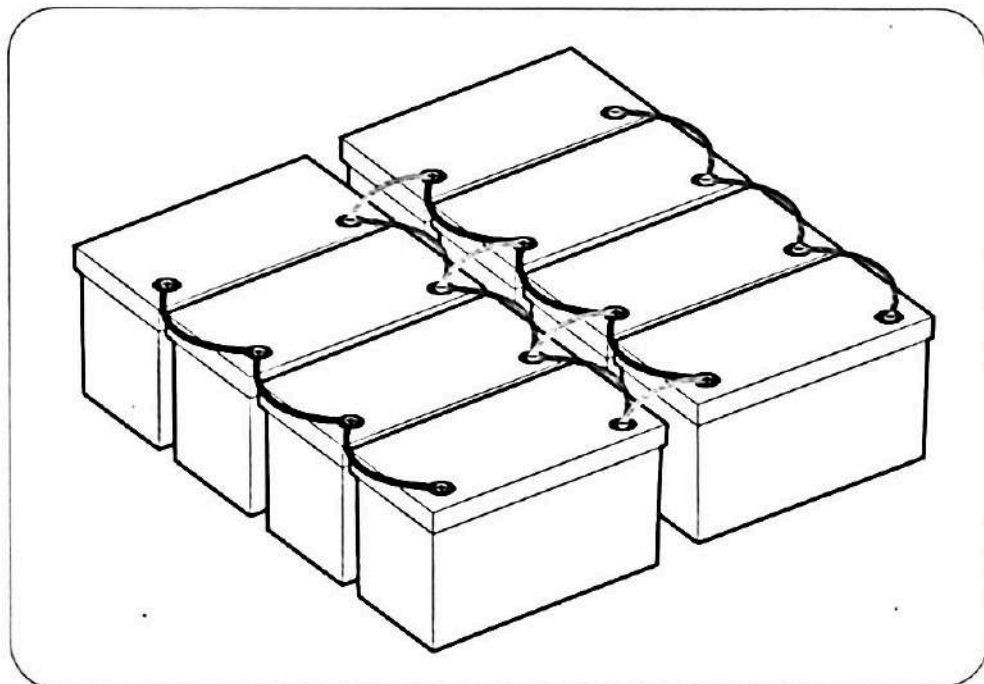

I Step4 Total Input & Output Connection

Use two **copper bars** (instead of battery terminals) to connect all the positive and negative output/input cables, ensuring that the input & output currents of each battery are balanced. (Not required when connecting batteries only in series.)

It is not recommended to use one terminal as the total positive or negative output/input of the battery system as the connected terminals may heat up or even melt if the total output/input current of the battery system is too high.

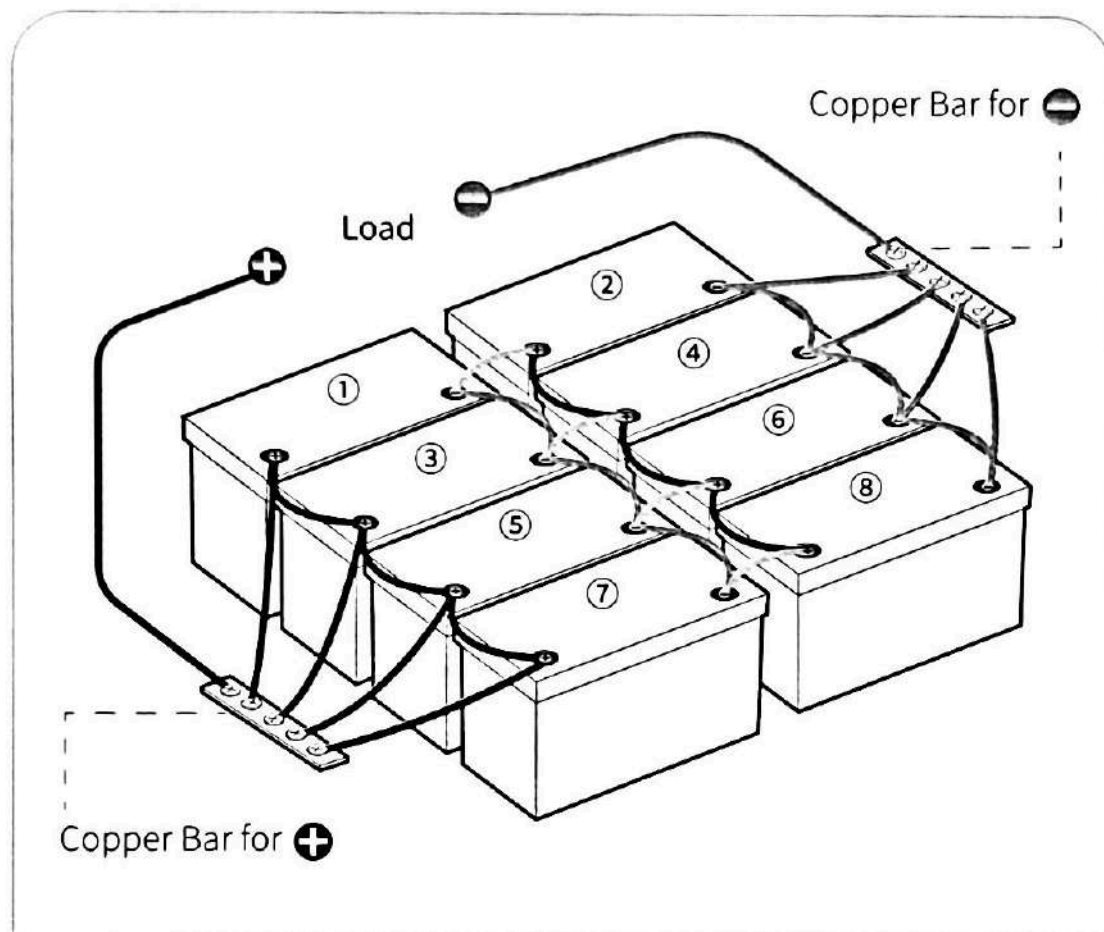

4P2S	Battery System	24V (25.6V) 400Ah
	Energy	10,240Wh
	Max. Continuous Charge / Discharge Current	400A
	Max. Continuous Load Power	10,240W

① As \ominus of ① / ③ / ⑤ / ⑦ is connected in series with \oplus of ② / ④ / ⑥ / ⑧, please do not connect \ominus of ① / ③ / ⑤ / ⑦ with \ominus of load or \oplus of ② / ④ / ⑥ / ⑧ with \oplus of load, otherwise the battery system will fail to connect in series.

② Please do not connect in reverse order, which may affect the use of the batteries.

Step 5 Rebalancing Every 6 Months

It is recommended to rebalance the battery voltage every six months following Step 2 on Page 10 if you're connecting multiple batteries as a battery system, as there might be voltage differences after six months of the battery system running.

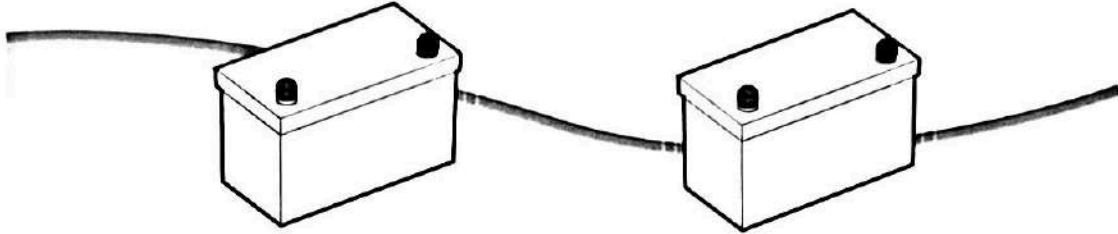

Wiring Diagrams

2P2S	Battery System	24V (25.6V) 200Ah
	Energy	5120Wh
	Max. Continuous Charge / Discharge Current	200A
	Max. Continuous Load Power	5120W

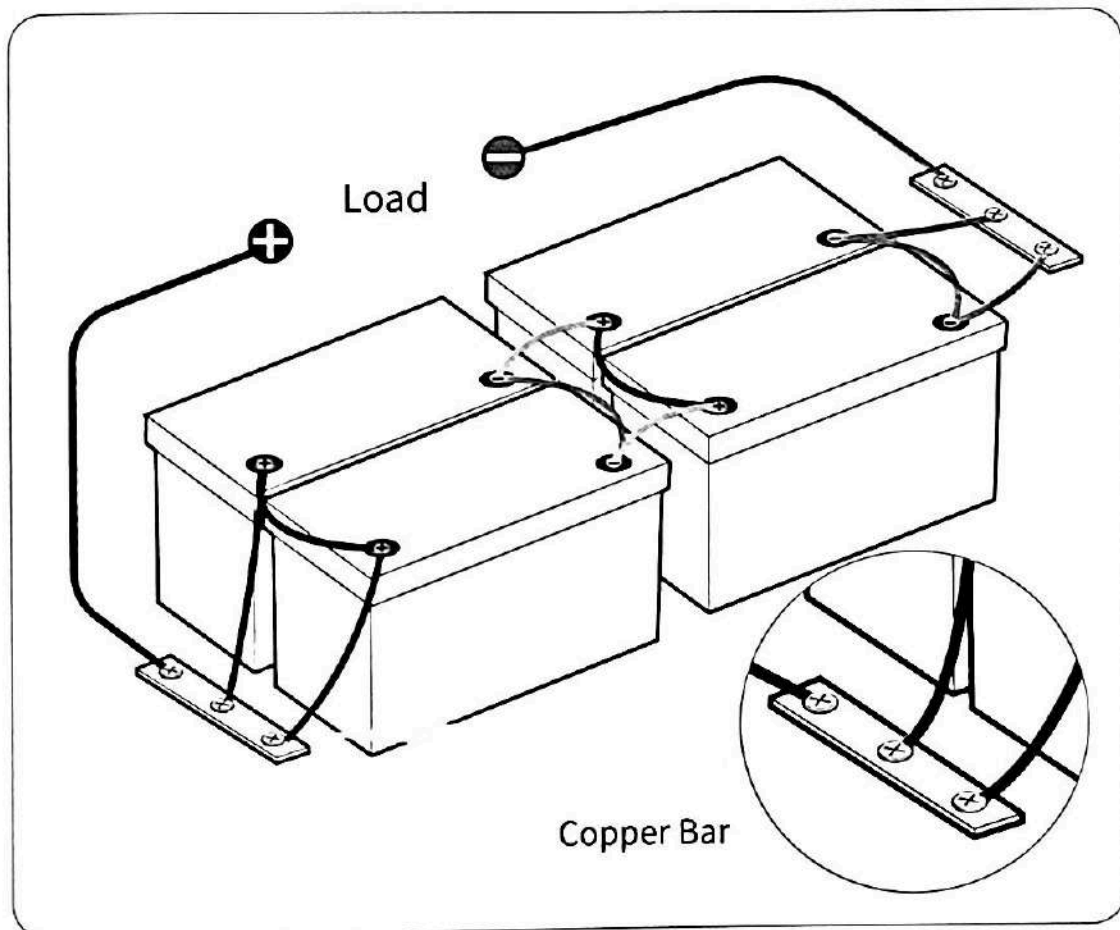

WHAT TO DO WHEN THE BATTERY STOPS WORKING?

When the battery

Can't work

or

Can't be charged

or



Voltage < 9v

It has 85% chances that BMS has shut it off for protection, and you could try one of below ways to activate the battery.

GENERAL STEPS

If the BMS has cut off the battery for protection, follow the below steps to activate it.

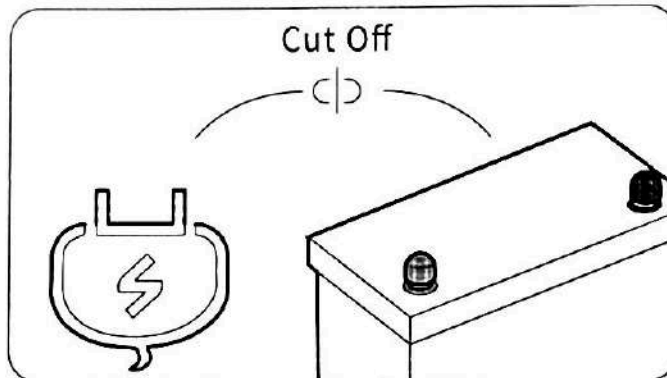
Step **1** Cut off all the connections from the battery



Step **2** Leave the battery aside for 30mins
Then the battery will automatically recover itself to normal voltage (>10V) and can be used after fully charged.

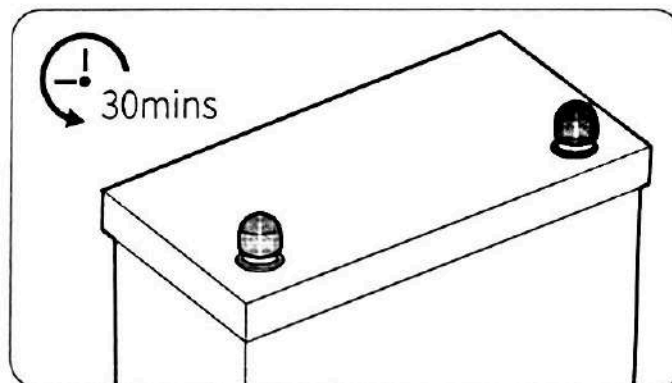

If the battery is unable to recover itself after the above steps, please try activating by **ONE OF BELOW TWO METHODS.**

After activated (voltage > 10V) and fully charged by the normal charging method, it can be used normally.

Method ①

Use a charger with a 0V charging function ① to fully charge the battery.

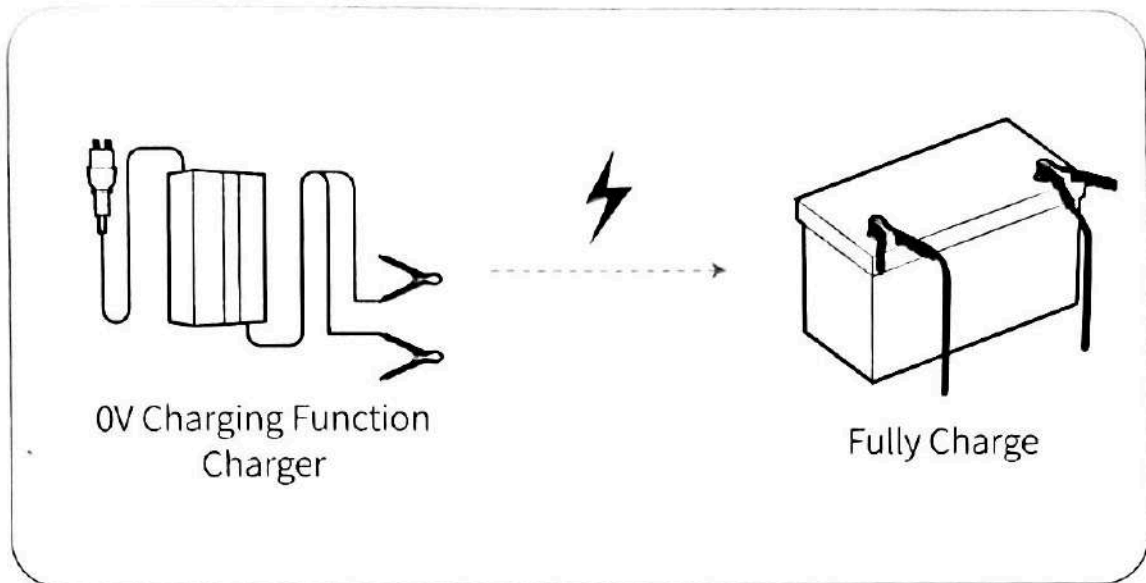

① The charger can charge the battery starting from 0V.

Method ②

Connect an 18V~36V solar panel to charge the battery for 3~10s in sunny daytime.

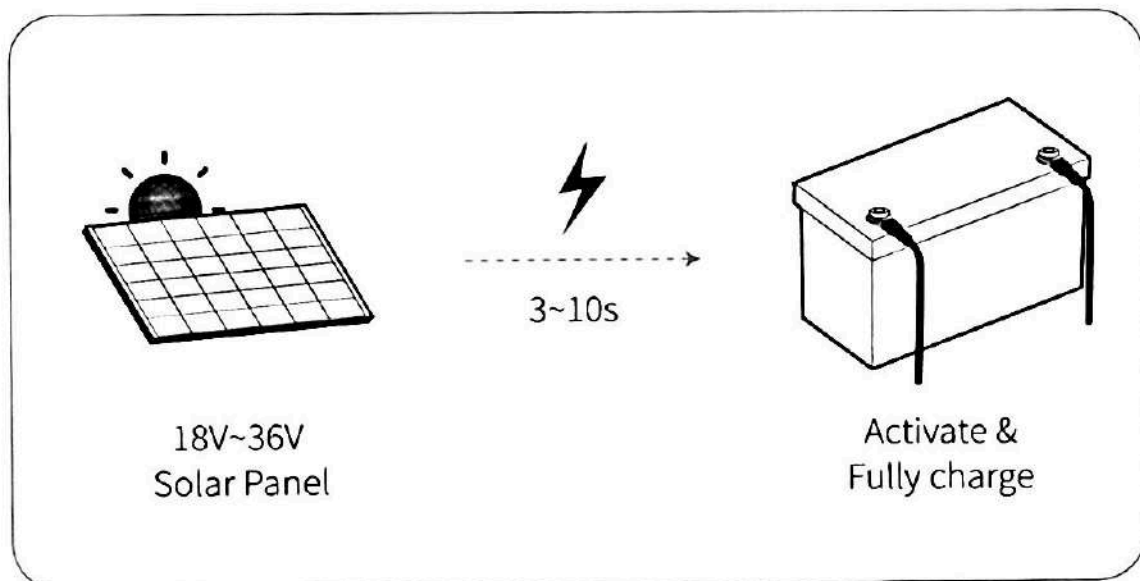

Li Time

Originate from Ampere Time

www.litime.com



Shenzhen Litime Technology Co., Ltd

 service@litime.com

 technicalsupport@litime.com